

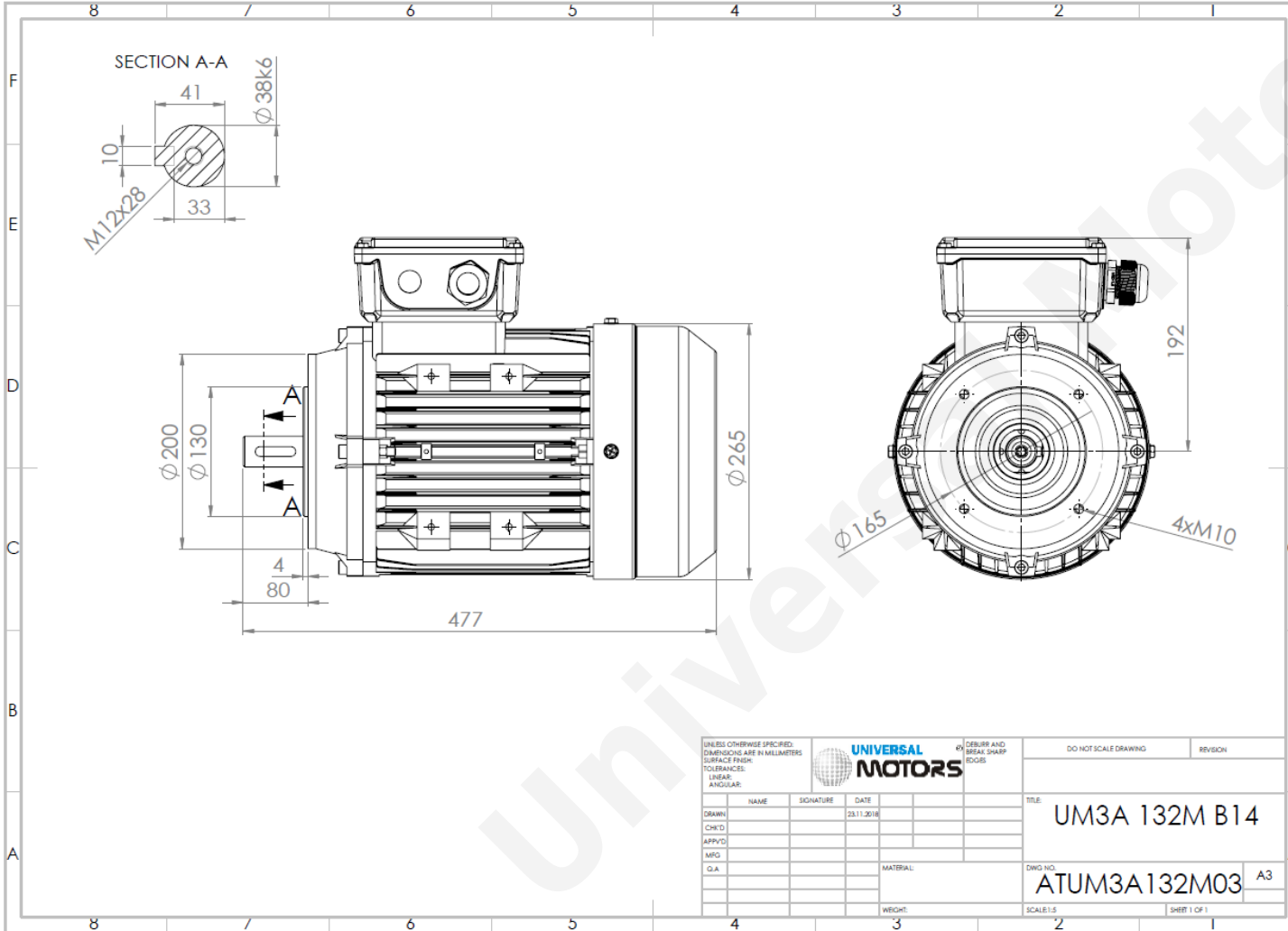

# TECHNICAL DATA

Three Phase Electric Motors - Aluminum Frame  
 PE31 132M-8  
 3 kW / 4 Cv  
 720 RPM



Motor type:	<b>PE31 132M-8</b>
Output:	<b>3 kW / 4 Cv</b>
Speed (min <sup>-1</sup> ):	<b>720 RPM</b>
Frequency:	<b>50 Hz</b>
Voltage:	<b>400 V</b>
Current:	<b>7.5 A</b>
Power factor (Cos $\phi$ ):	<b>0.700</b>
Poles:	<b>8</b>
Insulation class:	<b>F</b>
Temperature rise Class:	<b>B</b>
Efficiency 50%:	<b>82.9 %</b>
Efficiency 75%:	<b>84.8 %</b>
Efficiency 100%:	<b>84.2 %</b>
Torque:	<b>39.8 N.m</b>
Tstarting/Tnominal:	<b>2.5</b>
Istarting/Inominal:	<b>5.7</b>
Tmaximum/Tnominal:	<b>2.9</b>
Noise:	<b>73 Db(A)</b>
Weight:	<b>53.0 Kg</b>
Bearing DE:	<b>6308 2Z C3</b>
Bearing NDE:	<b>6308 2Z C3</b>

Regime - S1

Altitude - 1000m

Environment Temperature - 40°C

## CONTACTS:

UNIVERSAL MOTORS Tel: +351 252 299 080  
 Rua de São Brás,745 Fax: +351 252 299 089  
 4480-782 VILA DO CONDE Mail: [geral@universalmotors.pt](mailto:geral@universalmotors.pt)

\* References applied only in the UK